

REVISIONS			
REV.	DESCRIPTION	DATE	APPROVED
REL-01		7/16/2008	
REL-02	Added Layer of Plywood	7/22/2009	R.L.J.
REL-03	Added (1) 2x6	2/1/2013	M.F.K.

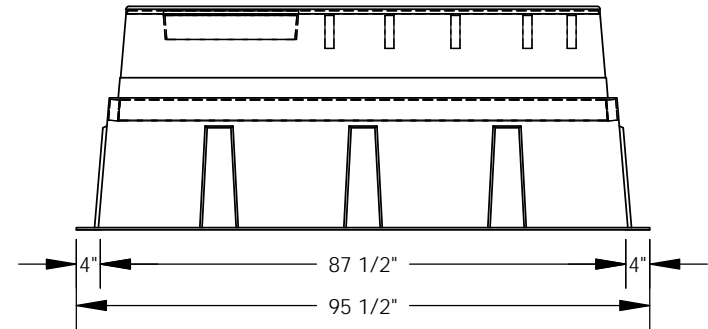
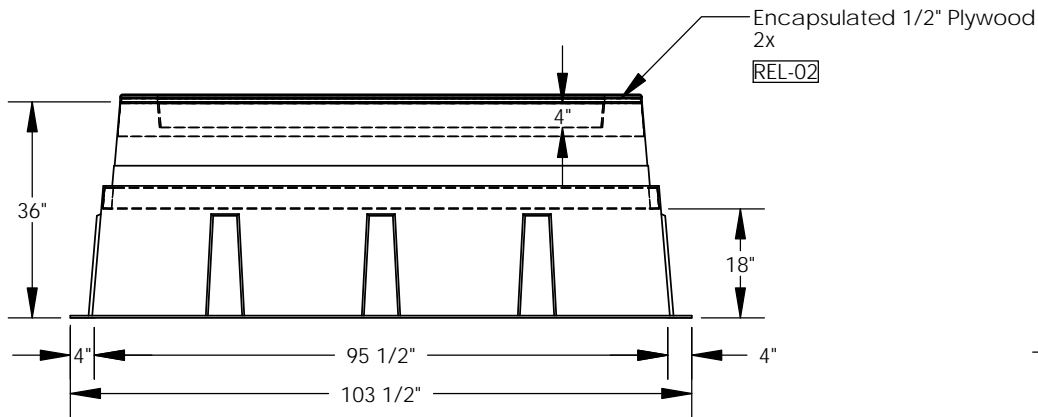
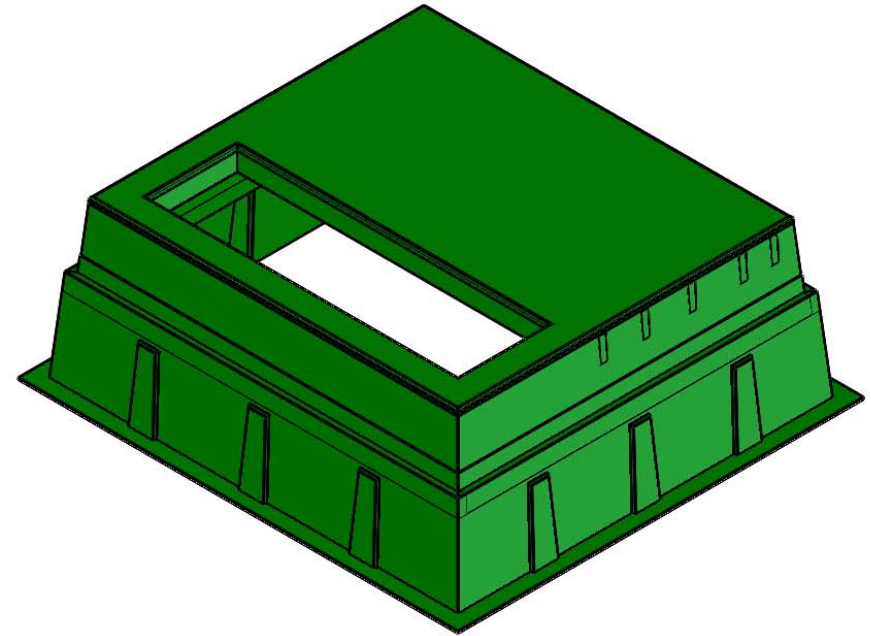
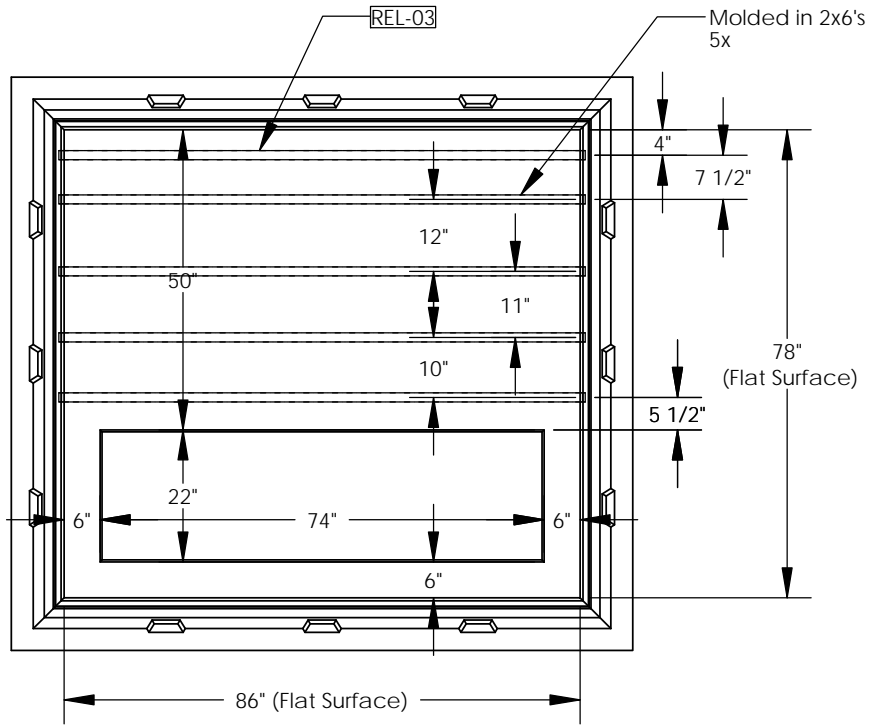

Proper installation of a box pad for transformers over 9,000 lbs. requires the soil to have a compaction level of 98% prior to setting the box pad. If that is not achievable, a cement pad/footing must be poured underneath the box pad prior to installation.

**Nordic Fiberglass, Inc.**

21415 US Hwy 75 NW, Warren, MN 56762  
www.nordicfiberglass.com  
218-745-5095 ph. --- 218-745-4990 fax

GS-86-78-36RT-2X-MG-74x22

**PROPRIETARY AND CONFIDENTIAL**  
THE INFORMATION CONTAINED IN THIS DRAWING IS THE SOLE PROPERTY OF NORDIC FIBERGLASS, INC. ANY REPRODUCTION IN PART OR AS A WHOLE WITHOUT THE WRITTEN PERMISSION OF NORDIC FIBERGLASS, INC. IS PROHIBITED.

Customer Name: N/A		
DIMENSIONS ARE IN INCHES TOLERANCES: ANGLES ± 1° FRACTIONAL ± 1/2 ONE PLACE DECIMAL ±.060 TWO PLACE DECIMAL ±.030 THREE PLACE DECIMAL ±.015		
MATERIAL		
DRAWN	NAME	DATE
CHECKED	---	--/--
	R.L.J.	03/17/08

SIZE	ITEM ID:	REV.
A	02015.00	REL-03
SCALE:1:30	SHEET 1 OF 1	