

AIS Padmounted Air-Insulated Switchgear 15 & 25 kV

Warranty - Material

Hubbell Power Systems, Inc. warrants all products sold by it to be merchantable (as such term is defined in the Uniform Commercial Code) and to be free from defects in material and workmanship. Buyer must notify the Company promptly of any claim under this warranty. The Buyer's exclusive remedy for breach of this warranty shall be the repair or replacement, F.O.B. factory, at the Company's option, of any product defective under the warranty which is returned to the Company within one year from the date of shipment. NO OTHER WARRANTY, WHETHER EXPRESS OR ARISING BY OPERATION OF LAW, COURSE OF DEALING, USAGE OF TRADE OR OTHERWISE IMPLIED, SHALL EXIST IN CONNECTION WITH THE COMPANY'S PRODUCTS OR ANY SALE OR USE THEREOF. The Company shall in no event be liable for any loss of profits or any consequential or special damages incurred by Buyer. The Company's warranty shall run only to the first Buyer of a product from the Company, from the Company's distributor, or from an original equipment manufacturer reselling the Company's product, and is non-assignable and non-transferable and shall be of no force and effect if asserted by any person other than such first Buyer. This warranty applies only to the use of the product as intended by Seller and does not cover any misapplication or misuse of said product.

Warranty - Application

Hubbell Power Systems, Inc. does not warrant the accuracy of and results from product or system performance recommendations resulting from any engineering analysis or study. This applies regardless of whether a charge is made for the recommendation, or if it is provided free of charge.

Responsibility for selection of the proper product or application rests solely with the purchaser. In the event of errors or inaccuracies determined to be caused by Hubbell Power Systems, Inc., its liability will be limited to the re-performance of any such analysis or study.

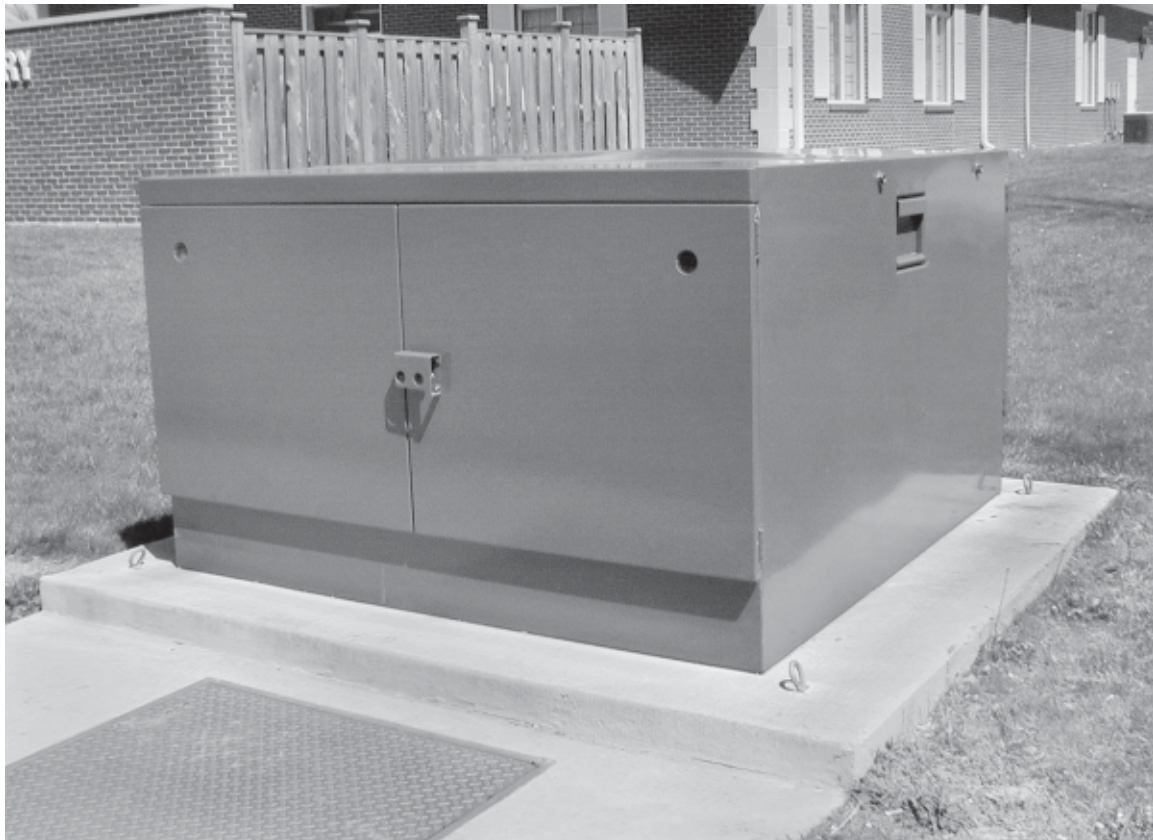

NOTE: Because Hubbell has a policy of continuous product improvement, we reserve the right to change design and specifications without notice.

©Copyright 2004 Hubbell • 210 North Allen Street • Centralia, MO 65240

HUBBELL / CHANCE – CENTRALIA, MISSOURI

MAY 2005
Printed in USA

CHANCE®

15 & 25 kV

Air-Insulated Deadfront Padmounted Switchgear

AIS switches combine . . .

Deadfront protection . . .

with Air Insulation benefits

Description

The AIS padmounted switch is an air-insulated, deadfront switch used for sectionalizing underground distribution systems. It is available in 15kV and 25kV ratings and in a variety of switch/fuse configurations. There are also extensive options available.

The AIS Switch is a true deadfront design with a sealed switching compartment, utilizing air as the insulating medium along with a deadfront connector system. This combination minimizes electrical exposure to work crews and the public, reduces outages, reduces maintenance requirements and provides the most cost effective solution for 15kV and 25kV underground system sectionalizing.

Features and Benefits of AIS Switches

True air-insulated deadfront design

Minimizing electrical exposure to work crews and the public

Reduces maintenance requirements

Reduces outages caused by vegetation and/or animal intrusion

Large viewing windows

Maximum visibility of 600A switch position and fuse condition

Built-in 9" base spacing

Increases door clearance and reduces the need for additional base spacers

No center door support

Increases working area in cable compartments

Replaceable 600A bushings

All 600A bushings are externally replaceable

AIS Ratings

Nominal Voltage	15kV	25kV
Maximum Design Voltage	15.5kV	29kV
BIL	95kV	125kV
One-Minute Withstand (60Hz)		
Switch and Terminators	35kV	60kV
Continuous Current Rating		
Switch Side	600 Amp	600 Amp
Fuse Side (Maximum)	200 Amp	200 Amp
Load Switching	600 Amp	600 Amp
Cable Charging Current	10 Amp	15 Amp
Magnetizing Current	21 Amp	21 Amp
Momentary and Making Current*	12,000 Amps, rms, symm	12,000 Amps, rms, symm
	19,200 Amps, rms, asymm	19,200 Amps, rms, asymm

*Consult factory for other requirements.

AIS Design Features

Switch Compartment

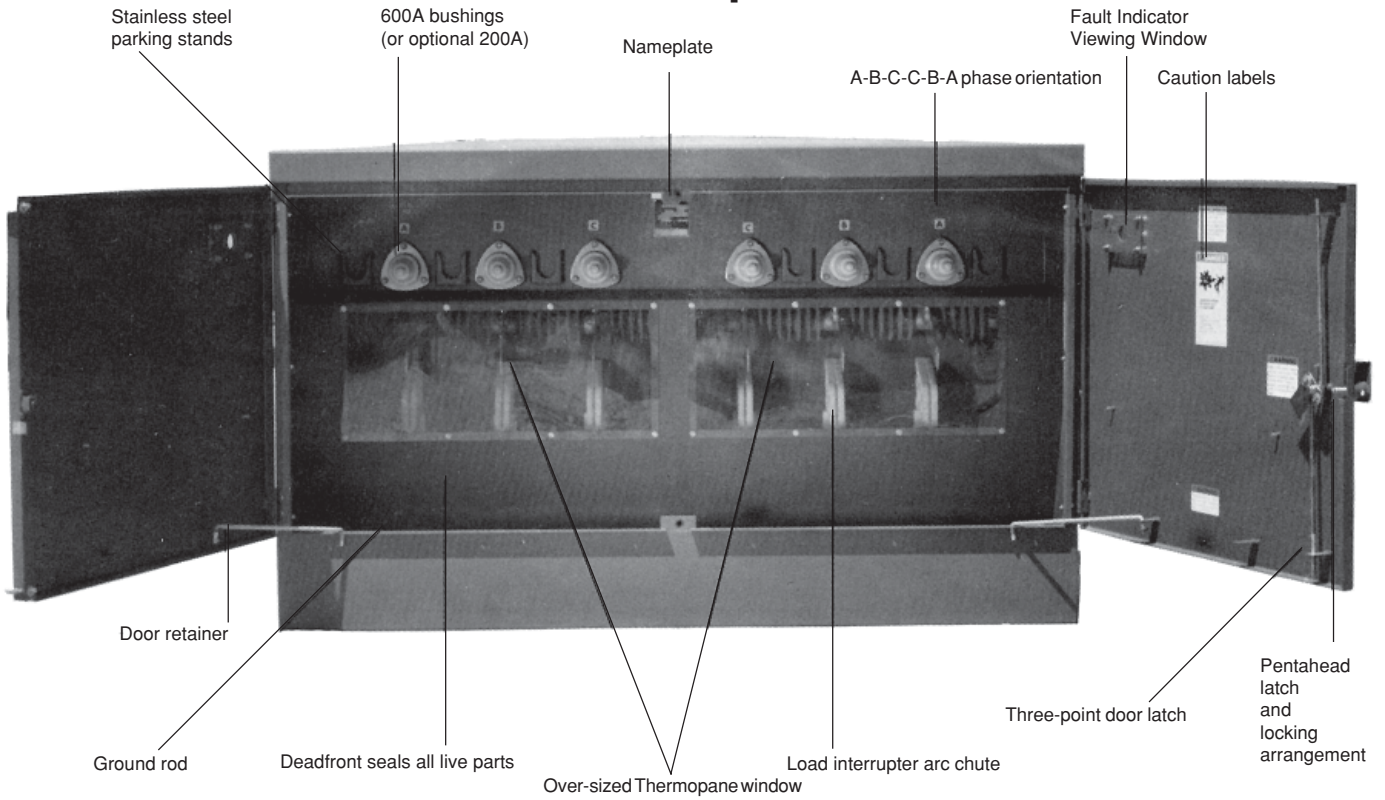

Fuse Compartment

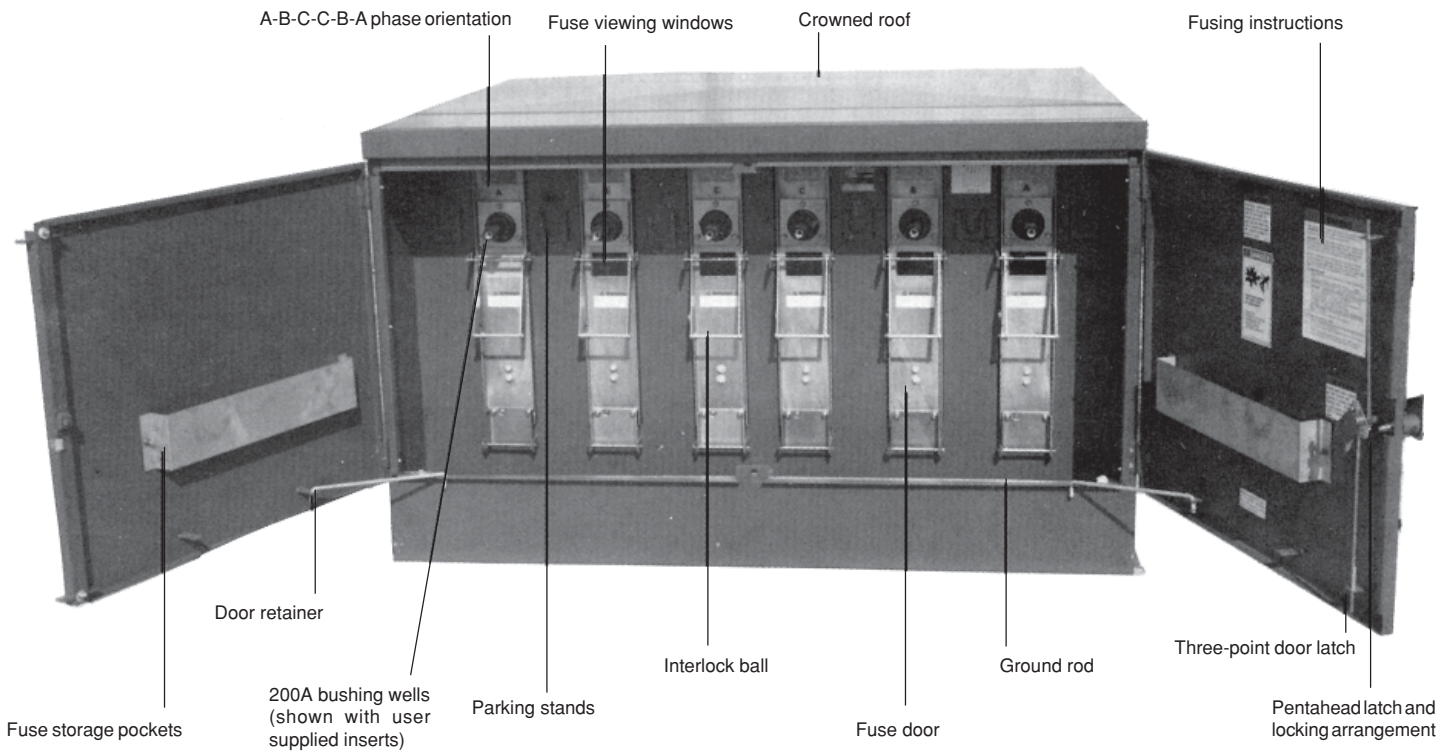

AIS Design Features

Structural Stability

The fully welded enclosure is constructed of heavy gauge steel for superior strength and durability. For applications in highly corrosive areas, stainless steel enclosures are available.

Exterior Protection

The surface of each enclosure undergoes a multistage chemical cleaning process. A powder coat finish is then applied for superior corrosion protection, durability and ultraviolet protection. This coating system meets the latest revision of ANSI Standard C57.12.28, "Padmounted Equipment Enclosure Integrity," and the EEI Paint Guidelines.

Door Latching System

The low-profile door latch assembly has no protruding handles. The pentahead on the right operates the three-point latch. The pentahead on the left secures the door to the center door jamb. Both pentaheads must be engaged before a padlock can be installed.

The latching system exceeds requirements in the latest revision of ANSI C57.12.28 and the Western Underground Committee Guide 2.13, "Security for Padmounted Equipment Enclosures."

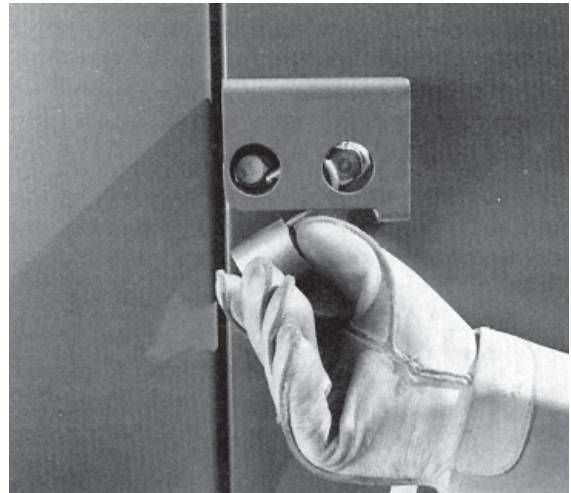

Externally Replaceable Bushings

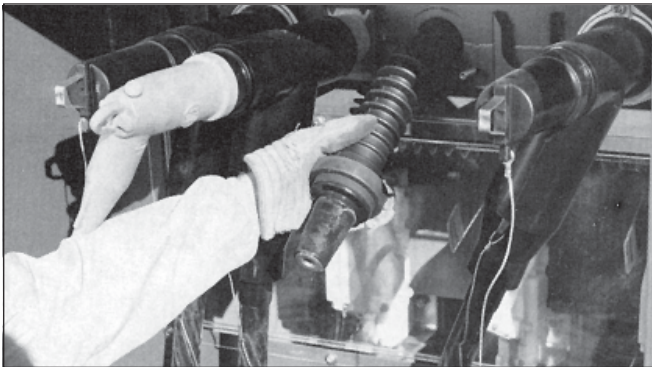

The 600A bushings on the AIS switch are truly externally replaceable. This feature allows the utility to quickly replace any bushings in the field without disassembling the faceplate. Due to the individualized sub-assembly design, the AIS may be provided with 200A bushing wells in lieu of 600A bushings.

External Side Operator

An external operating mechanism is housed on the outside of the center compartment and allows linemen to perform switching functions without opening the cable compartment. Each three-phase gang switch is equipped with its own operator. The external operator can be padlocked in either the open or closed position.

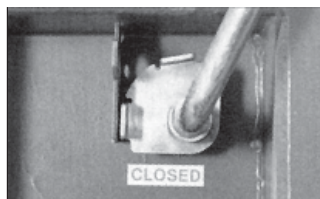

A sturdy operating handle is stored in each operator compartment. The padlocking provisions on the compartment doors accommodate the majority of available padlocks.

Padmount Interchangeability

The AIS is designed to be pad interchangeable with competitive designs. Base adapters also are available to make the AIS compatible with pads for some live front gear.

Visible Break

Oversized Thermopane windows provide excellent viewing for verification of visible break. The large windows are constructed of heavy-duty, mar-proof double pane polycarbonate. They are easily removed in the shop to provide ready access to switch components.

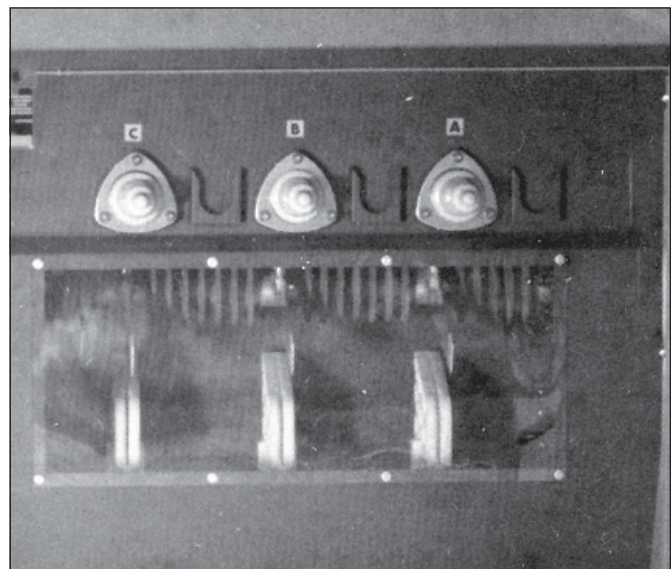

Confirming the visible break through the AIS windows eliminates the need to move the 600A connectors.

Fusing Flexibility

Fuse versatility was a key design parameter of the AIS in order to utilize existing fuses already approved and in use by the utility and/or to improve coordination with existing fuse systems. A utility using livefront gear can use the same fuses and end fittings in the AIS.

- S&C SMU-20 power fuse
- S&C SM-4Z power fuse
- Cooper type NX current limiting fuse

For S&C fuses, indicator windows are provided for locating blown fuses. Fuse doors are mechanically interchangeable and require only a simple operation, without de-energizing the 600 amp line side, to change in the field from one type fuse to another.

Horizontal Feed-Through Bushings



Sufficient space is provided for feed-through bushings for parking of elbows.

Fuse Access is Safe and Simple

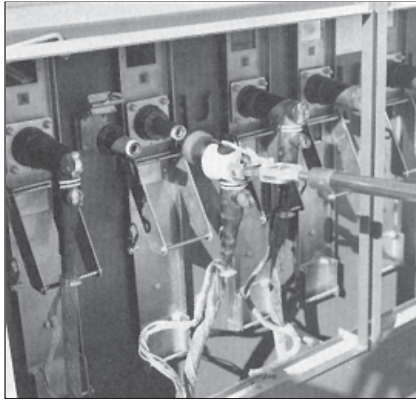

1 - Loadbreak elbow must be removed before the mechanical latch can be opened. Parking the elbow insures that the load is safely disconnected.



2 - After the elbow has been parked, the latching bail on the fuse door is released.

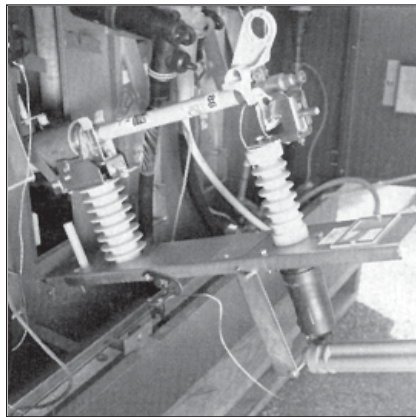

3 - As fuse door is lowered, a spring-activated barrier closes behind it to maintain the deadfront integrity of the switch's tap side.

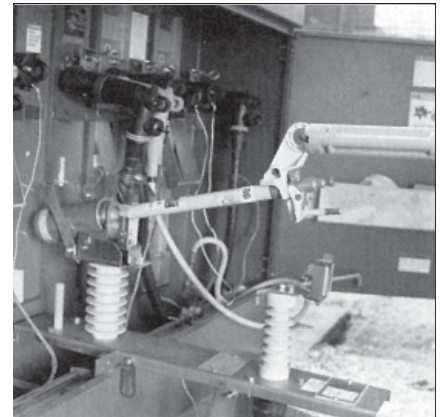

4 - When the fuse door is fully opened, the fuse tray is positioned an ample distance from the cables for easy removal of the fuses.

FEEDER ISOLATION does not require movement of the 600A connectors.

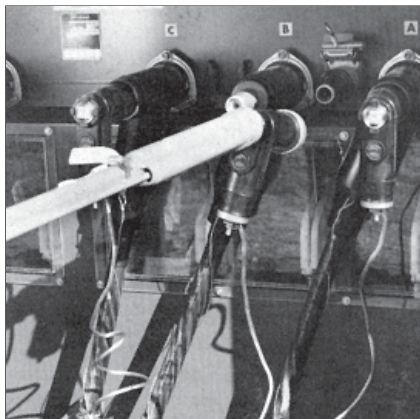

After verification of visible break, removal of the arrester exposes the load reducing tap plug on back of the 600A connector.



A Chance Multi-Range Voltage Detector may be used to test for line voltage.

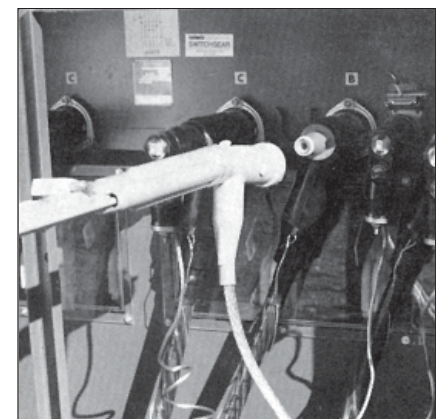

The Feeder can then be grounded with a standard grounding elbow.

AIS Reliability

ANSI Design Tests

The AIS has been tested to rigorous specifications of the Standard for Deadfront Padmounted Switchgear, ANSI C37.72. Traditionally, switchgear was subjected to a variety of tests which imposed individual switches to the extremes of interrupting duty, momentary, make-and-latch, dielectric and mechanical tests. As a result of unanimous utility input to the Standards Committee, the design test requirements in the new standard were substantially changed. Now, a single switch must be subjected to a sequence which combines and expands all the rigors previously imposed on individual switches. The design test sequence consists of the following tests in the order indicated:

1. Interrupting Current Test
2. Momentary Current Test
3. Making Current Test
4. 60-Hertz Withstand Test
5. Thermal Runaway Test
6. Mechanical Operation Test

After completing the design test sequence, the switch must be capable of carrying rated current without thermal runaway. In addition, the design must pass a 60-Hertz, direct current and impulse test as well as one-second high current, corona and temperature rise tests. While the above tests in themselves are all very important, Chance does not stop at this point in their evaluation of new switch designs. Various other visual, mechanical, electrical and environmental tests are conducted to assure optimum performance.

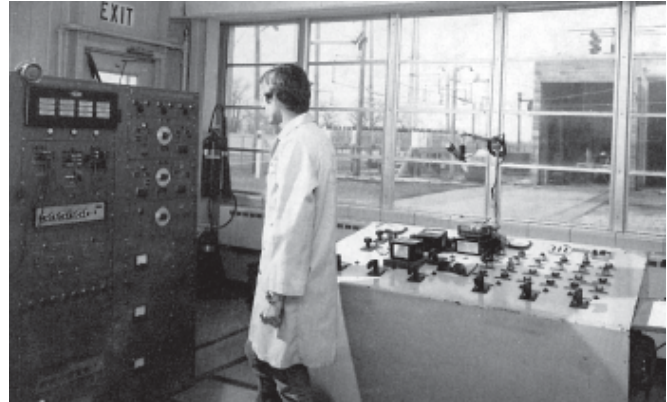





The AIS switch undergoes various tests in the Chance Research Center and its testing laboratory complex.

Production Testing

After assembly, all switches are tested to ANSI Standards:

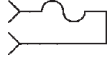
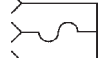
1. Voltage Drop Test (IR). Each line direction of the switch configuration is tested. The IR test is a current test where the voltage drop across the area tested is measured to indicate the impedance in the circuit which is tested. This test assures reliable electrical connections.
2. High Potential Testing. Each switch is tested phase-to-phase and phase-to-ground across the insulation system with the switch in the open and closed positions.

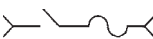
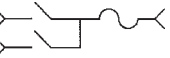
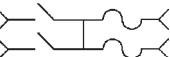
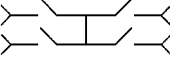
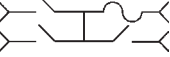
Ordering Information: 15 and 25 kV AIS Padmounted Sectionalizing Equipment

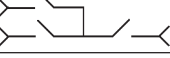
Switch Configuration	One-Line Diagram	Voltage kV		Termination & Bus Ratings — Amps				Phases
		Nom.	BIL	Line 1	Line 2	Line 3	Line 4	
AIS-1		15/25	95/125	200	200	—	—	1
AIS-1A		15/25	95/125	200	200	200	—	1
AIS-3		15/25	95/125	600*	600*	—	—	3
AIS-5		15/25	95/125	600*	200	—	—	3
AIS-6		15/25	95/125	600*	600*	—	200	3
AIS-9		15/25	95/125	600*	600*	200	200	3
AIS-10		15/25	95/125	600*	600*	600*	600*	3
AIS-11		15/25	95/125	600*	600*	600*	200	3
AIS-12		15/25	95/125	200	600*	200	200	3
AIS 13A		15/25	95/125	600*	600*	600*	—	3

* 200A universal bushing wells can be supplied instead of 600A deadbreak bushings.

AIS Switch Catalog Number System

X X X X X X X X X X X

kV Rating

- A 15kV
- B 25kV

Switch Configuration

- 010 AIS-1
- 01A AIS-1A
- 030 AIS-3
- 050 AIS-5
- 060 AIS-6
- 090 AIS-9
- 100 AIS-10
- 110 AIS-11
- 120 AIS-12
- 13A AIS-13A

Source Connector Provisions

- A 600A deadbreak bushings
- B 200A universal bushing wells

NOTE: All fuse connector provisions are supplied with 200A universal bushing wells. 200A universal bushing well inserts are not provided.

00 No fusing (i.e. AIS-3, AIS-10, AIS-13A)

Options

- C1 Removable stud 600A bushings
- D1 Automatic door latch (standard with stainless steel, option F).
- E 6" base adapter to allow mounting AIS switch on the pad of a different manufacturer's switch of the same configuration (contact factory for specific details and availability).
- F Stainless steel enclosure
- G Kirk Key Interlocks to prevent paralleling source side switches.
- H Kirk Key interlocks to prevent entry to fuse doors without all feed switches locked open.
- I 200A bushing well inserts
- L Kirk Key Interlocks combining options G and H
- Q 6" base spacer
- U 12" base spacer
- V 18" base spacer
- W 24" base spacer

Fusing: For 15 kV AIS Select the appropriate fuse from table below:				
Fuse Manufacturer	Fuse Mounting	Ratings		Catalog Number Additions
		Maximum Design kV	Maximum Amperes, RMS	
S&C	SM-20	17.0	200	20 ⁽¹⁾
S&C	SM-4Z	17.0	200	4Z ⁽²⁾
Cooper	NX	8.3	1.5-40	N1
Cooper	NX	8.3	50-100	N2
Cooper	NX	15.5	1.5-40	N3
Cooper	NX	15.5	50-100	N3

Fusing: For 25 kV AIS Select the appropriate fuse from table below:				
Fuse Manufacturer	Fuse Mounting	Ratings		Catalog Number Additions (Suffix)
		Maximum Design kV	Maximum Amperes, RMS	
S&C	SM-20	27	200	20 ⁽¹⁾
S&C	SM-4Z	27	200	4Z ⁽²⁾
Cooper	NX	15.5	1.5-40	N1
Cooper	NX	15.5	50-100	N2
Cooper	NX	23	6-40	N3
Cooper	NX	27	6-50	N3

(1) To include SML20 End Fittings, change "20" to "2H"

(2) To include SM4Z End Fittings, change "4Z" to "4H"

PAD™ Controller for Padmount Switch Automation

The PAD™ controller for AIS switchgear provides utilities with the most advanced and economical approach to automation. The easy-to-install PAD is adaptable to any AIS padmount as well as those of other manufacturers.

Two-way, three-way, and four-way switching is available.

PAD Electrical Features

- Six status indications for position indication, charger status, loss of AC, and battery condition.
- Motor runs on AC or battery for double reliability.
- Temperature compensating battery charger
- “Smart” battery disconnect to prevent damage to the battery from deep discharge
- “No-Go” function with status indication to prevent underpowered switch operation.
- User-friendly travel set control – You’ll love it!!
- Local/remote switch
- Open/close switch with LED position indication
- Vented 12 V .33 A-H lead acid battery
- AC receptacle
- Surge protection to ANSI C37.90 and C62.41
- Grounding provision
- Thermostatically controlled heater



PAD™ Mechanical Features

- Provision for manual operation
- Padlockable motor
- Decoupler with lockout provision
- Powder-coated aluminum enclosure with stainless steel continuous hinge and handle hardware
- Instruction book pocket



Specific PAD[™] Model Features

PAD[™] motor operator to automate the AIS padmount loadbreak switch featuring:

Catalog No. ABCCB33HB01

Features —

- Aluminum enclosure with green finish
- PAD mounting kit
- Version III circuit control assembly
- 12 V, vented battery
- Battery fuse and block
- Battery charger
- AC fuse and block
- MOV surge protection
- 125 V / 250 watt heater and thermostat
- Front panel with indicating lights and motor travel setting controls
- AC convenience outlet
- Provision for mounting customer RTU and radio

Catalog No. ABCCB33HB02

Features —

Same as above except without provision for mounting RTU and radio for use on switches with two or more motor operators. RTU and Radio are only required in one unit.

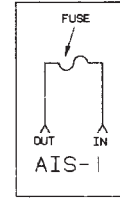
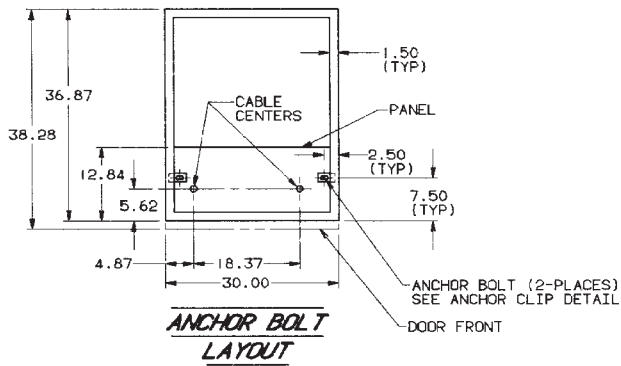

CIRCUIT DIAGRAM

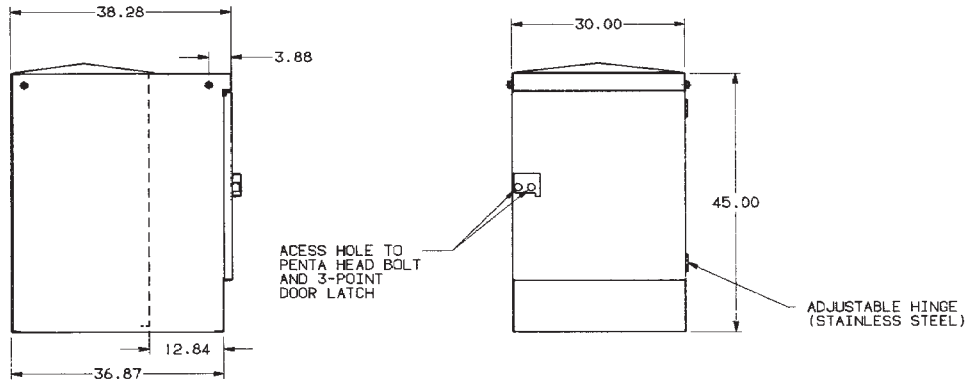

Model AIS-1
25kV — 125kV - BIL
 weight 650 lb.

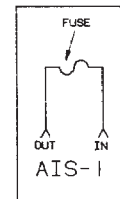
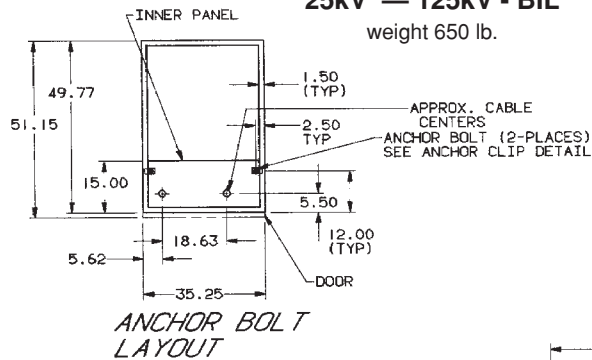

CIRCUIT DIAGRAM

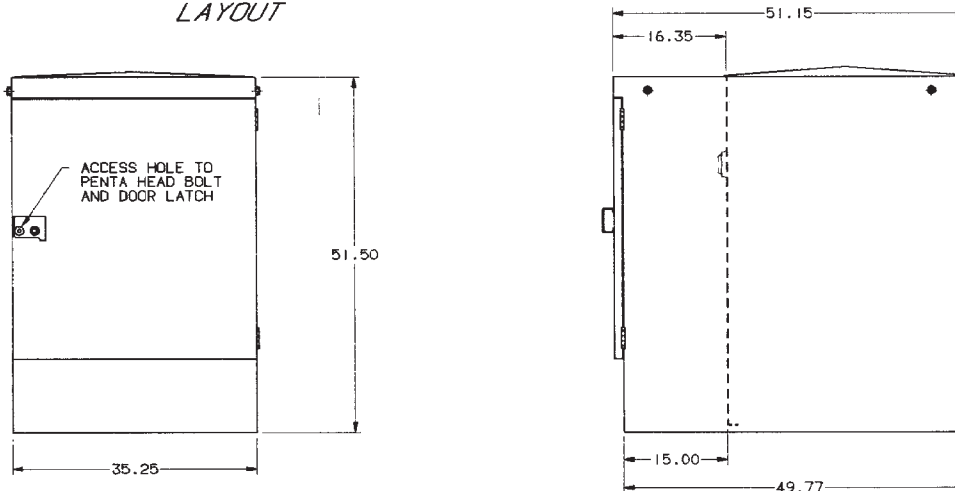



CHANCE

17D-11

Model AIS-1A
15kV — 95kV - BIL
weight 475 lb.

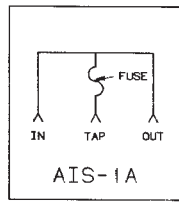

CIRCUIT DIAGRAM

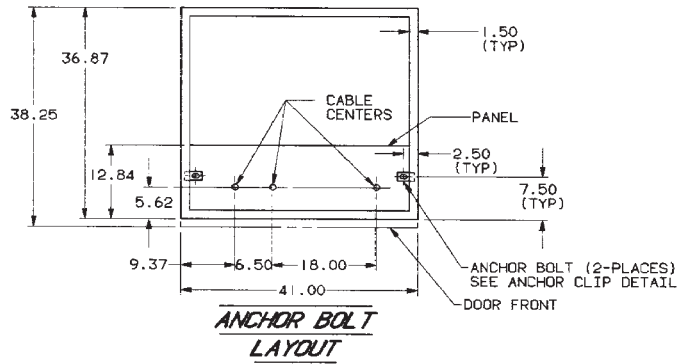

ANCHOR BOLT LAYOUT

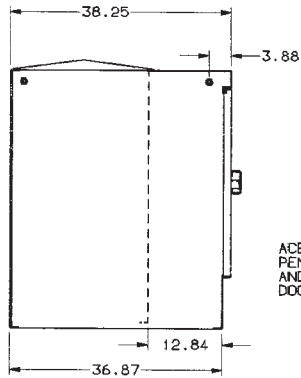

ACCESS HOLE TO PENTA HEAD BOLT AND 3-POINT DOOR LATCH

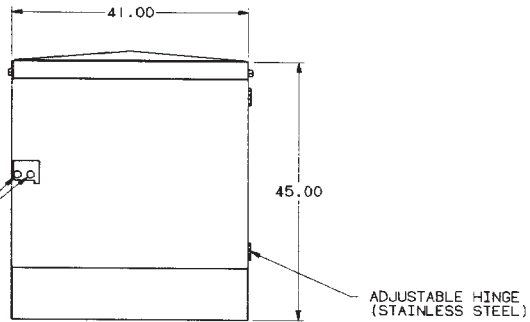

ADJUSTABLE HINGE (STAINLESS STEEL)

Model AIS-1A
25kV — 125kV - BIL
weight 694 lb.

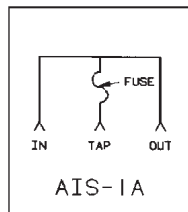

CIRCUIT DIAGRAM

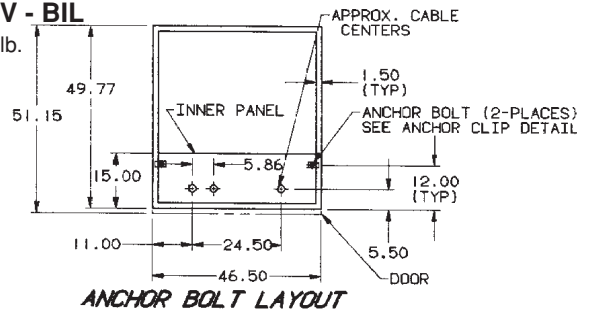

ANCHOR BOLT LAYOUT

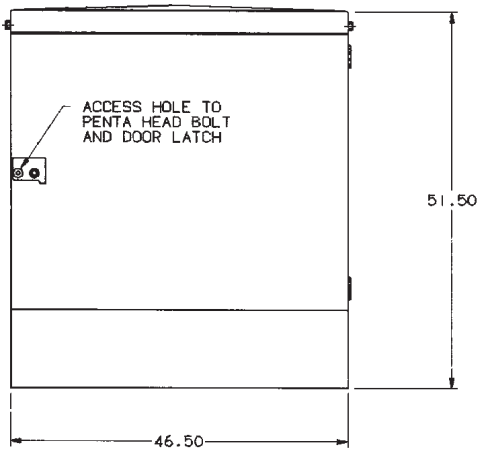

ACCESS HOLE TO PENTA HEAD BOLT AND DOOR LATCH

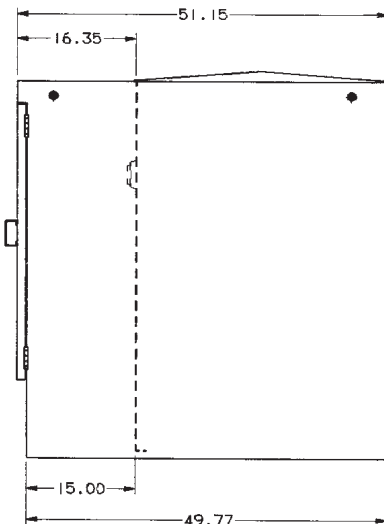

Model AIS-3
15kV — 95kV - BIL
 weight 875 lb.

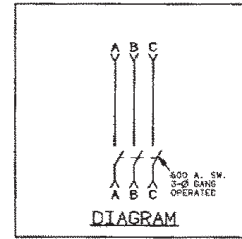
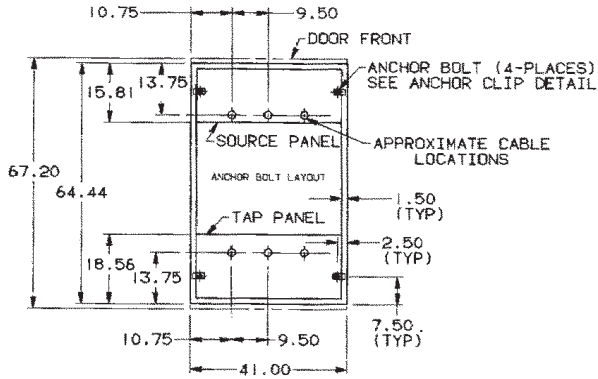

AIS-3
CIRCUIT DIAGRAM

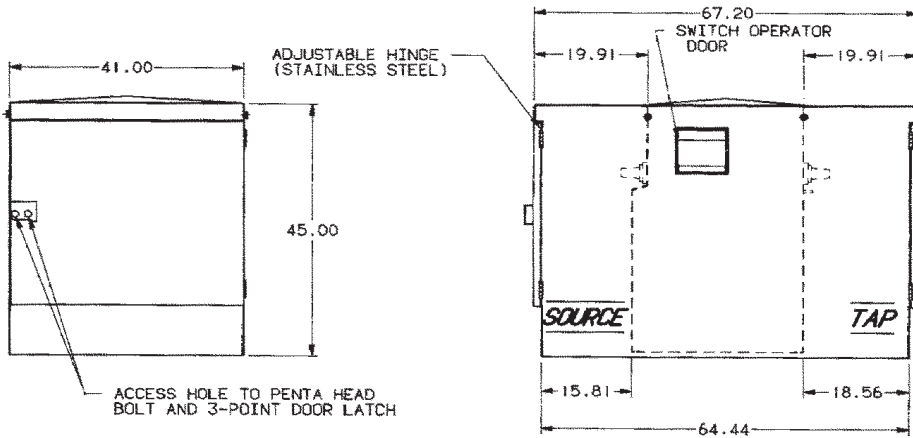

Model AIS-3
25kV — 125kV - BIL
 weight 1275 lb.

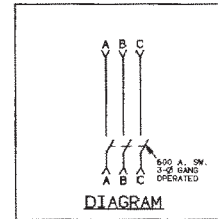
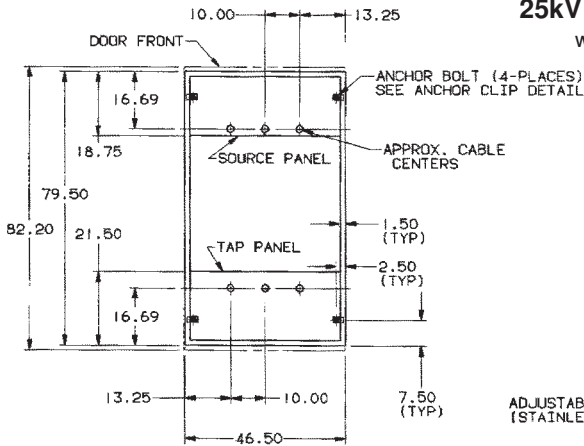

AIS-3
CIRCUIT DIAGRAM

ANCHOR BOLT LAYOUT

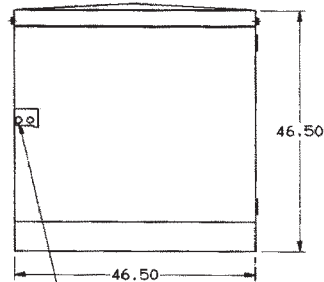

ACCESS HOLE TO PENTA HEAD BOLT AND DOOR LATCH

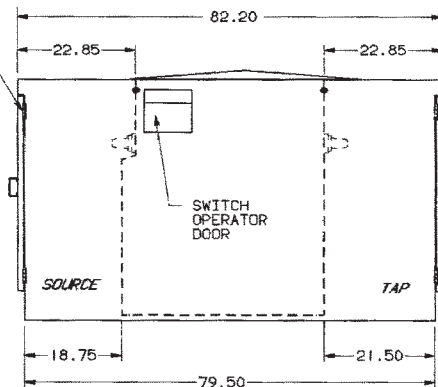



CHANCE

17D-13

Model AIS-5
15kV — 95kV - BIL
weight 900 lb.

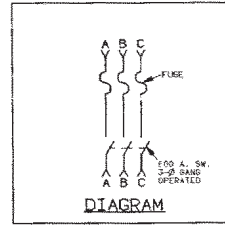
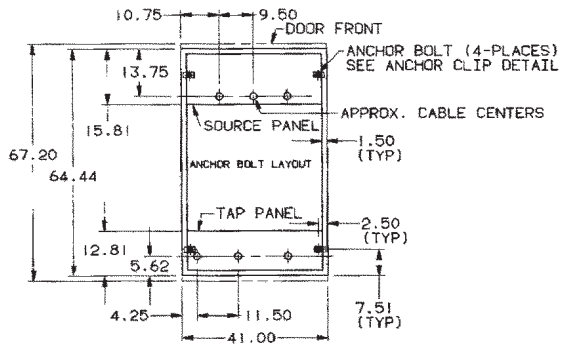

AIS-5
CIRCUIT DIAGRAM

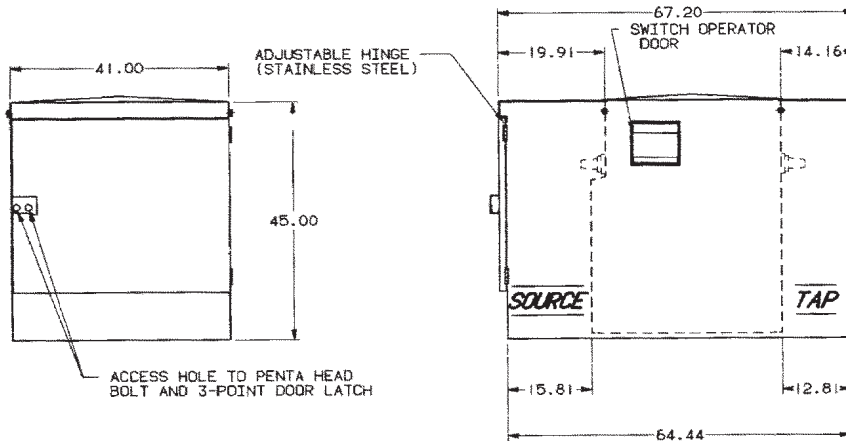

Model AIS-5
25kV — 125kV - BIL
weight 1350 lb.

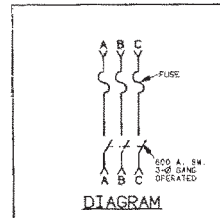
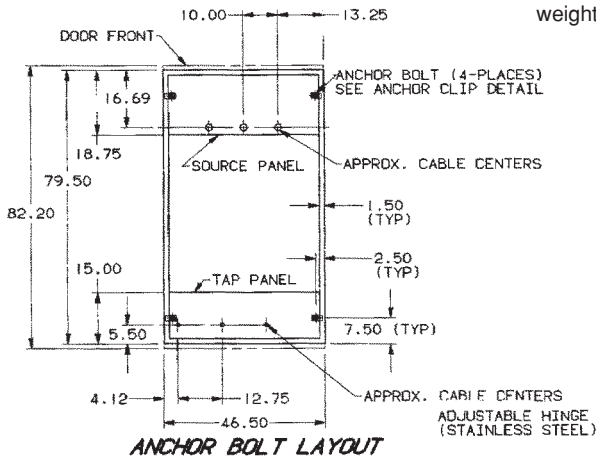

AIS-5
CIRCUIT DIAGRAM

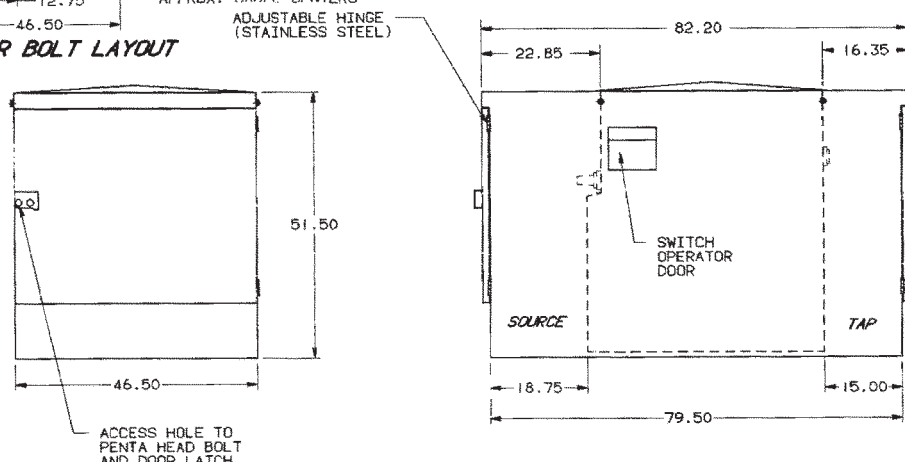

Model AIS-6 15kV — 95kV - BIL

weight 1450 lb.

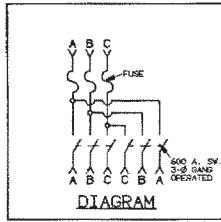

AIS-6
CIRCUIT DIAGRAM

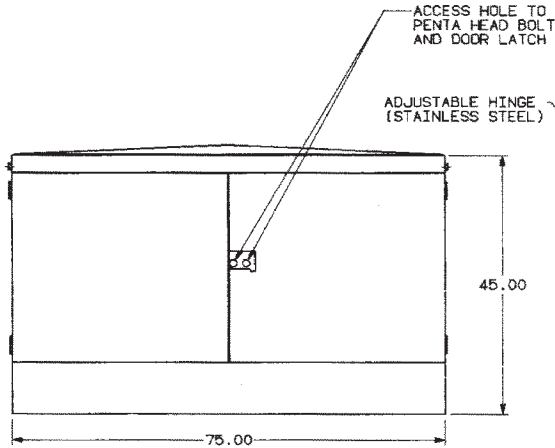
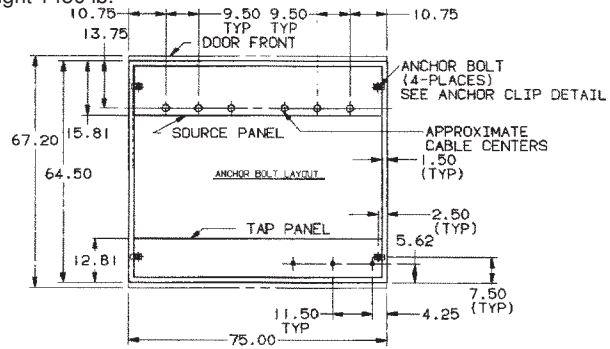

ADJUSTABLE HINGE (STAINLESS STEEL)

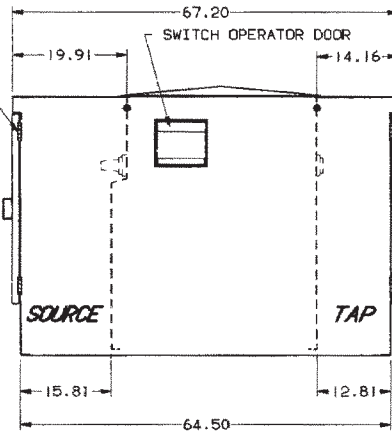

Model AIS-6 25kV — 125kV - BIL

weight 1950 lb.

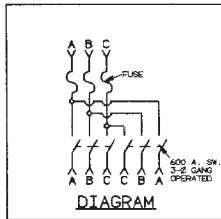

AIS-6
CIRCUIT DIAGRAM

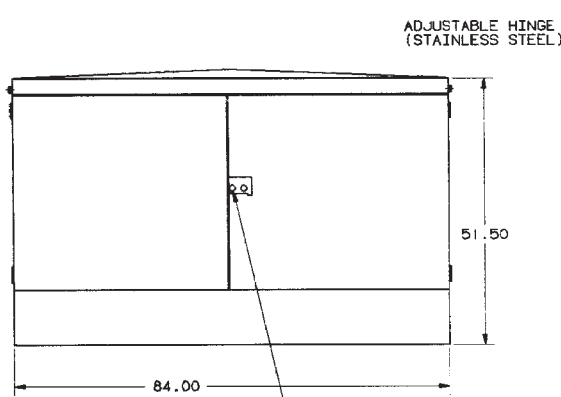
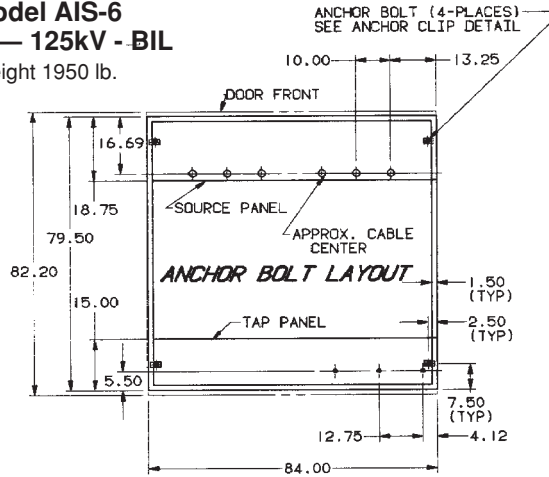

ADJUSTABLE HINGE (STAINLESS STEEL)

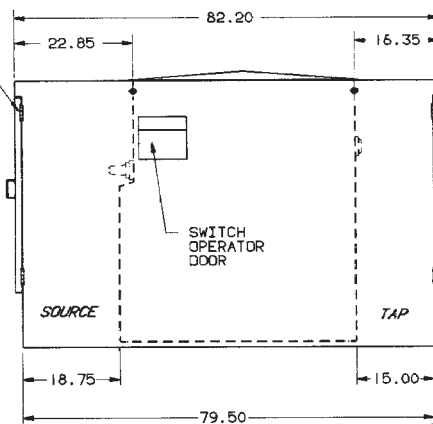



CHANCE

17D-15

Model AIS-9

15kV — 95kV - BIL POWER SYSTEMS, INC.

weight 1500 lb.

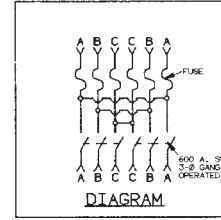
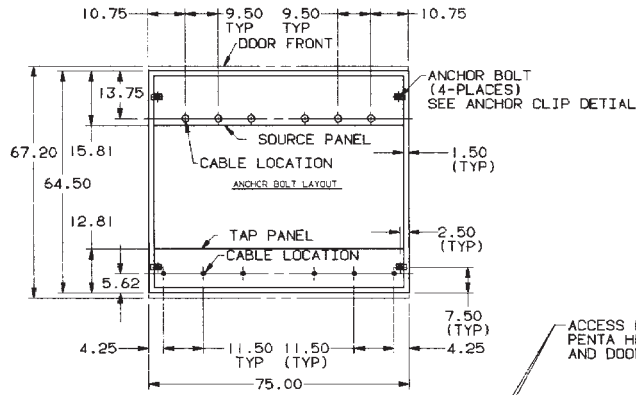

AIS-9
CIRCUIT DIAGRAM

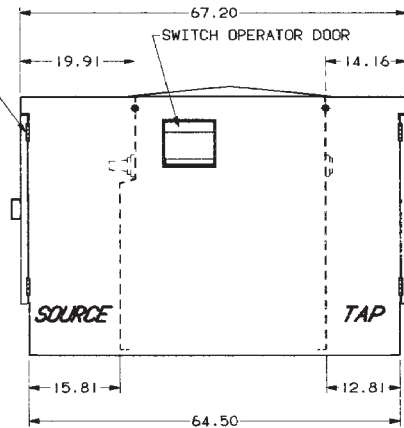
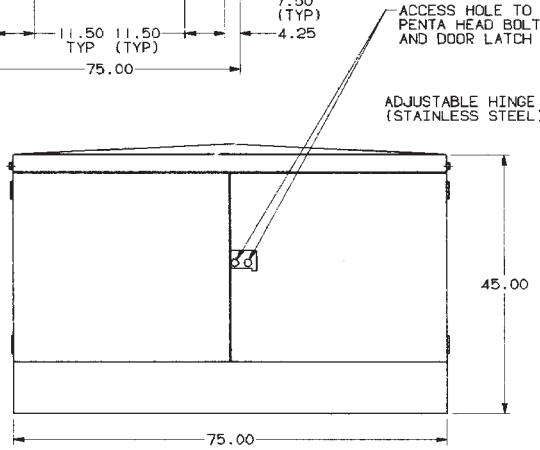

Model AIS-9 25kV — 125kV - BIL

weight 2000 lb.

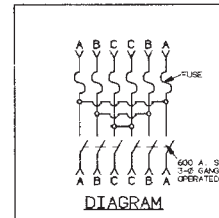
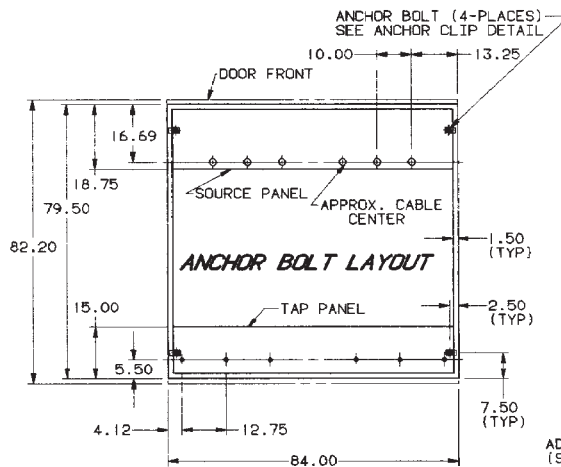

AIS-9
CIRCUIT DIAGRAM

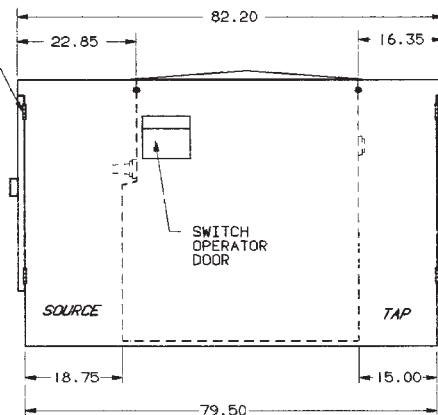
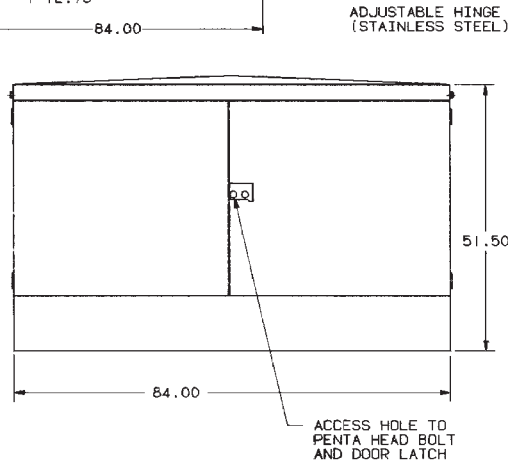

Model AIS-10
15kV — 95kV - BIL
 weight 1650 lb.

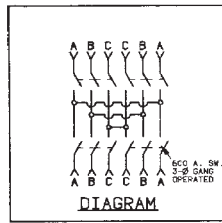

AIS-10
CIRCUIT DIAGRAM

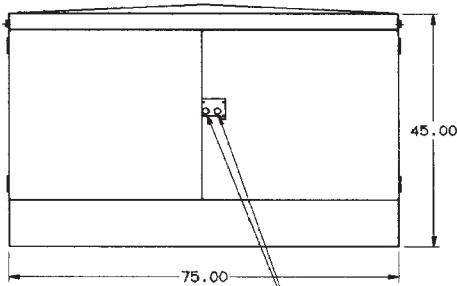
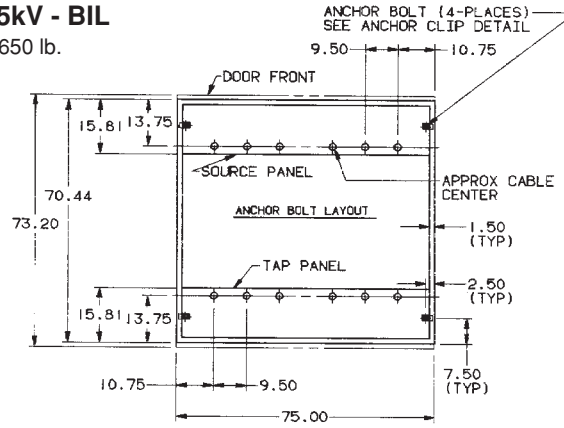

ACCESS HOLE TO
 PENTA HEAD BOLT
 AND 3-POINT DOOR
 LATCH

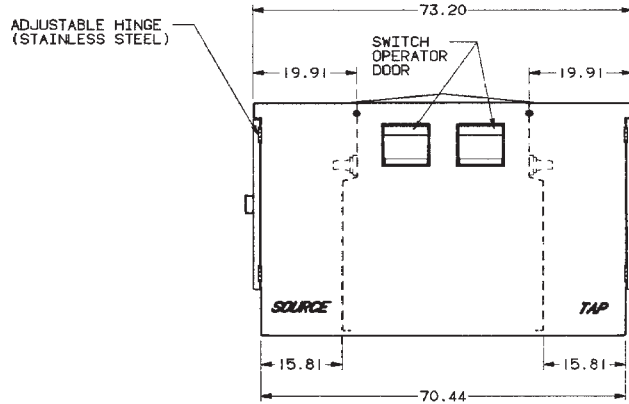

Model AIS-10
25kV — 125kV - BIL
 weight 2000 lb.

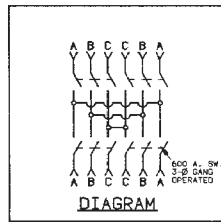

AIS-10
CIRCUIT DIAGRAM

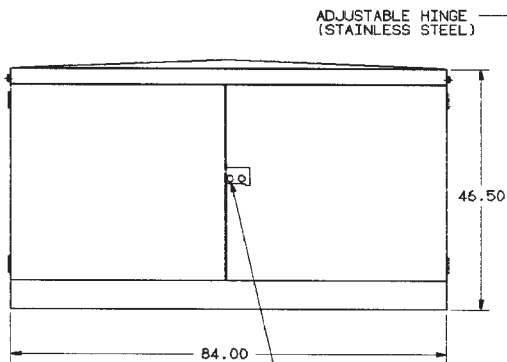
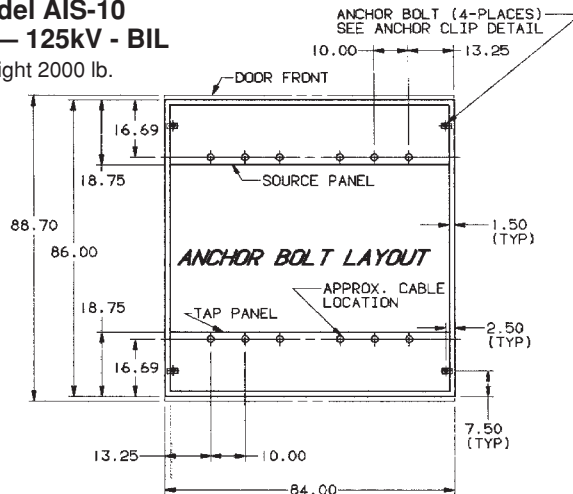

ACCESS HOLE TO
 PENTA HEAD BOLT
 AND DOOR LATCH

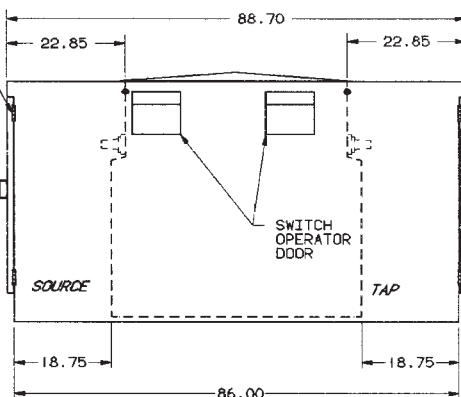



Model AIS-11

15kV — 95kV - BIL

weight 1650 lb.

POWER SYSTEMS, INC.

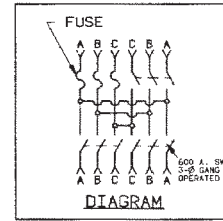
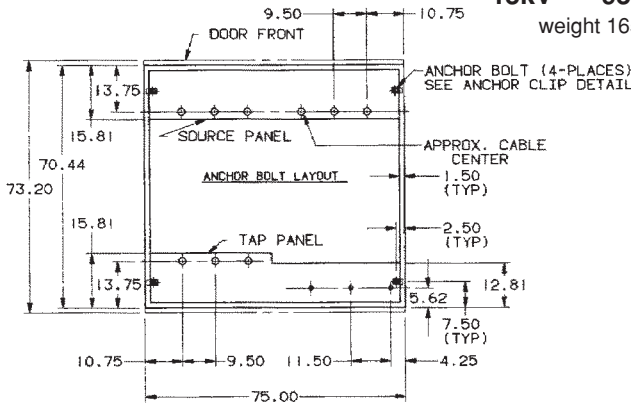

AIS-11
CIRCUIT DIAGRAM

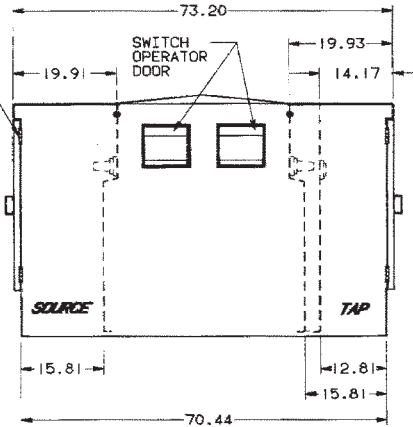
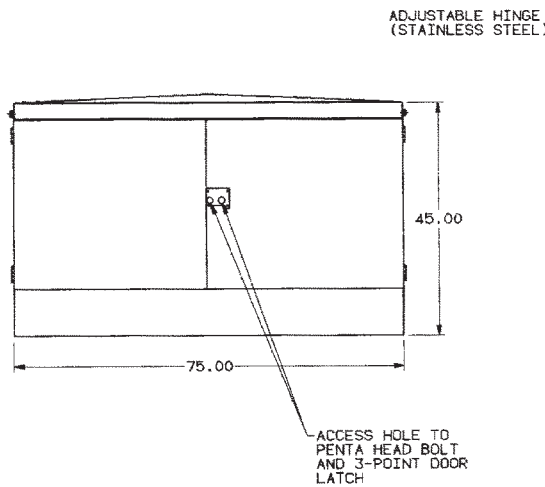

Model AIS-11

25kV — 125kV - BIL

weight 2200 lb.

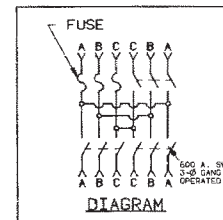
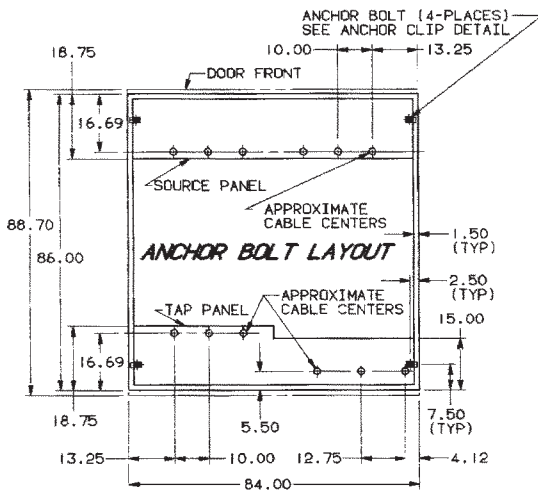

AIS-11
CIRCUIT DIAGRAM

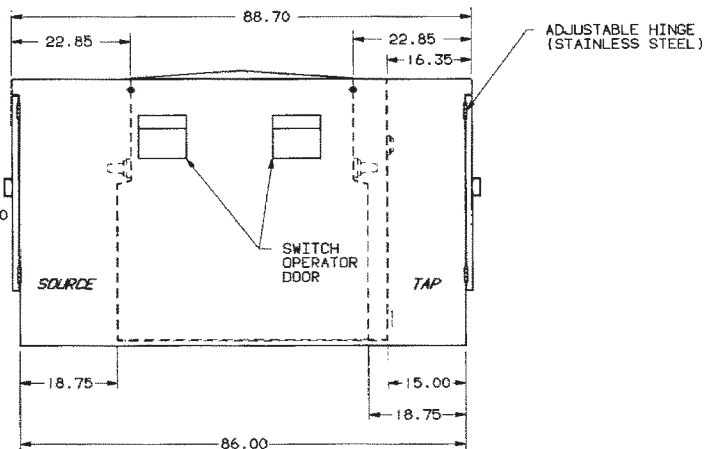
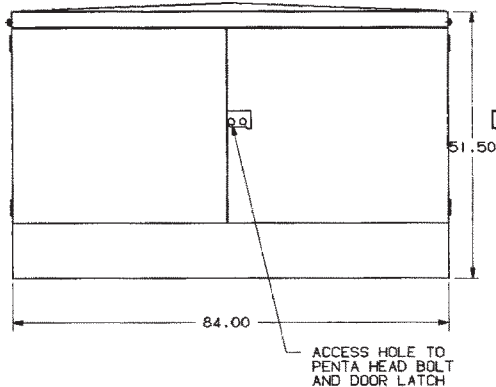

Model AIS-12
15kV — 95kV - BIL

weight 1550 lb.

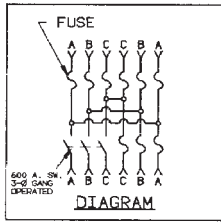

AIS-12
CIRCUIT DIAGRAM

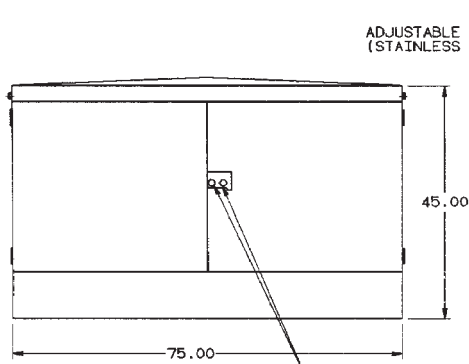
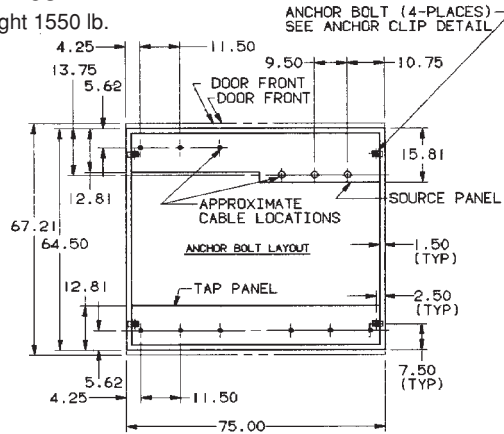

ACCESS HOLE TO
PENTA HEAD BOLT
AND 3-POINT DOOR
LATCH

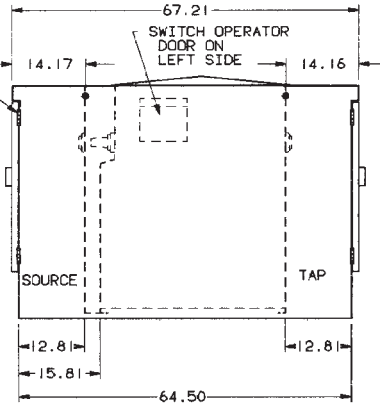

Model AIS-12
25kV — 125kV - BIL

weight 2075 lb.

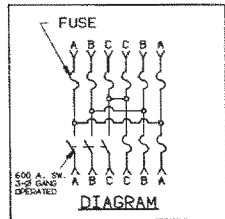

AIS-12
CIRCUIT DIAGRAM

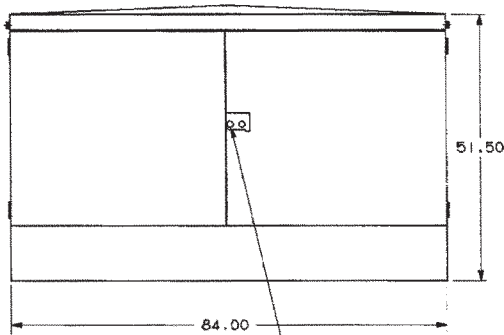
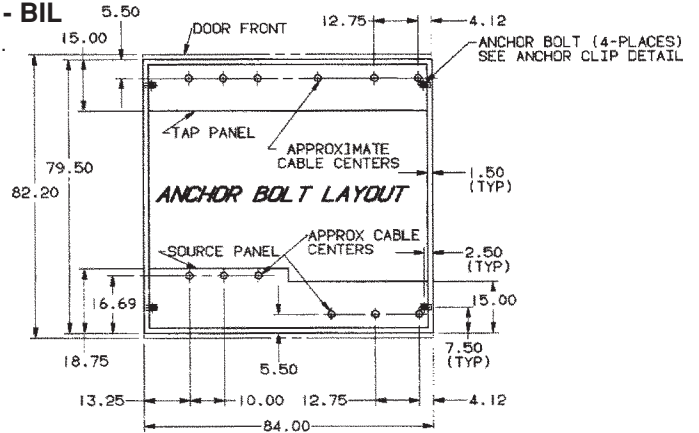

ACCESS HOLE TO
PENTA HEAD BOLT
AND DOOR LATCH

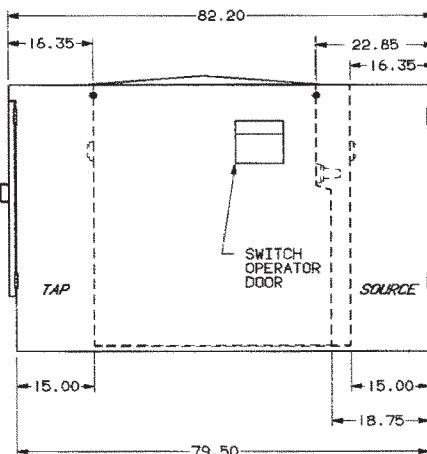



Model AIS-13A
15kV — 95kV - BIL POWER SYSTEMS, INC.

weight 1600 lb.

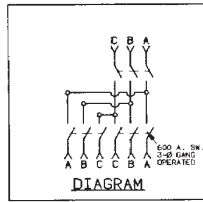

AIS-13A
CIRCUIT DIAGRAM

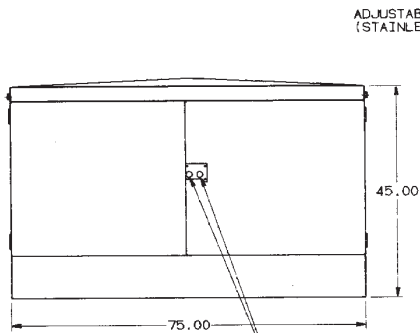
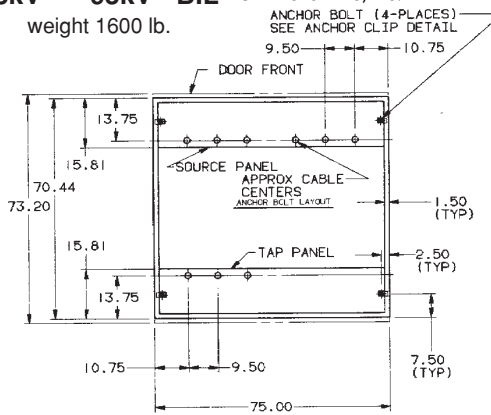

ACCESS HOLE TO
PENTA HEAD BOLT
AND 3-POINT DOOR
LATCH

ADJUSTABLE HINGE
(STAINLESS STEEL)

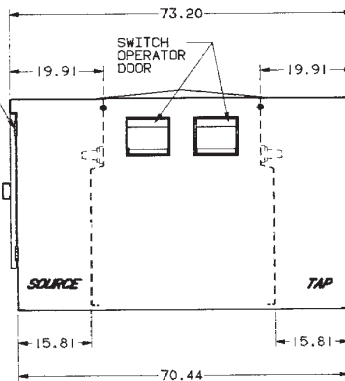

Model AIS-13A
25kV — 125kV - BIL

weight 1950 lb.

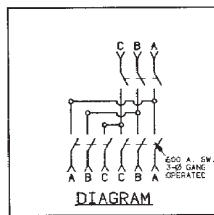

AIS-13A
CIRCUIT DIAGRAM

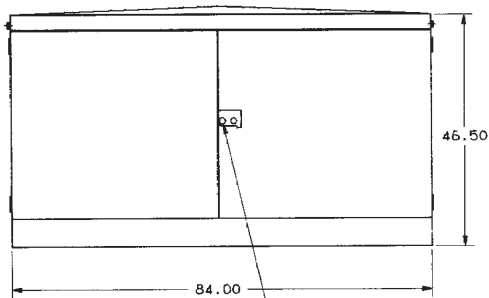
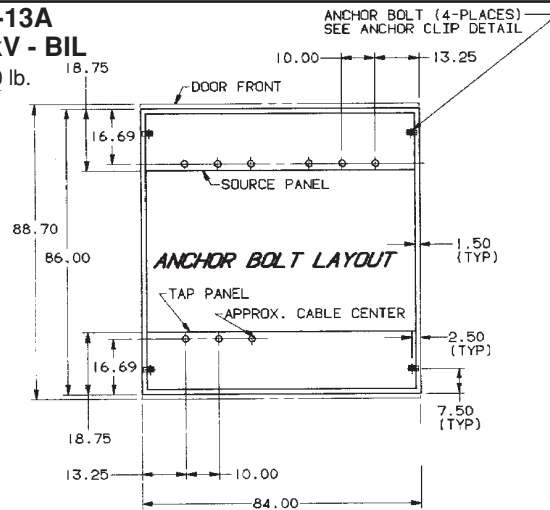

ACCESS HOLE TO
PENTA HEAD BOLT
AND DOOR LATCH

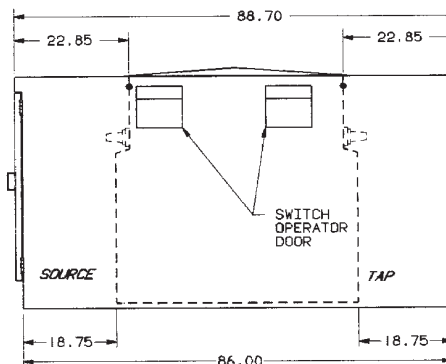

ADJUSTABLE HINGE
(STAINLESS STEEL)



POWER SYSTEMS, INC.



WORLDWIDE LOCATIONS

**Web: <http://www.hubbellpowersystems.com>
E-mail: hpsliterature@hps.hubbell.com**

UNITED STATES

HUBBELL POWER SYSTEMS, INC.
210 N. Allen
Centralia, Mo 65240-1395
Phone: 573-682-5521
Fax: 573-682-8714
e-mail: hpscontact@hps.hubbell.com

CANADA

HUBBELL CANADA, INC.
870 Brock Road South
Pickering, Ontario L1W 1Z8
Phone: 905-839-1138
Fax: 905-831-6353
e-mail: infohps@hubbellonline.com

MEXICO

HUBBELL DE MEXICO, S.A. DE. CV
Av. Coyoacan No. 1051
Col. Del Valle
03100 Mexico, D.F.
Phone: 52-55-9151-9999
Fax: 52-55-9151-9988
e-mail: vtasdf@hubbell.com.mx

ASIA

HUBBELL S.E. ASIA PTE. LTD.
23 Tagore Lane #03-16
Tagore 23 Warehouse
Singapore 787601
Phone: 65-6454-4772
Fax: 65-6454-4775
e-mail: hpscontact@hps.hubbell.com

ANDERSON™ CHANCE® FARGO® HUBBELL® OHIO/BRASS®