

REVISIONS			
REV.	DESCRIPTION	DATE	APPROVED
REL-01		3/1/2006	
REL-02	Updated Cover to Injection Molded	12/1/2009	R.L.J.

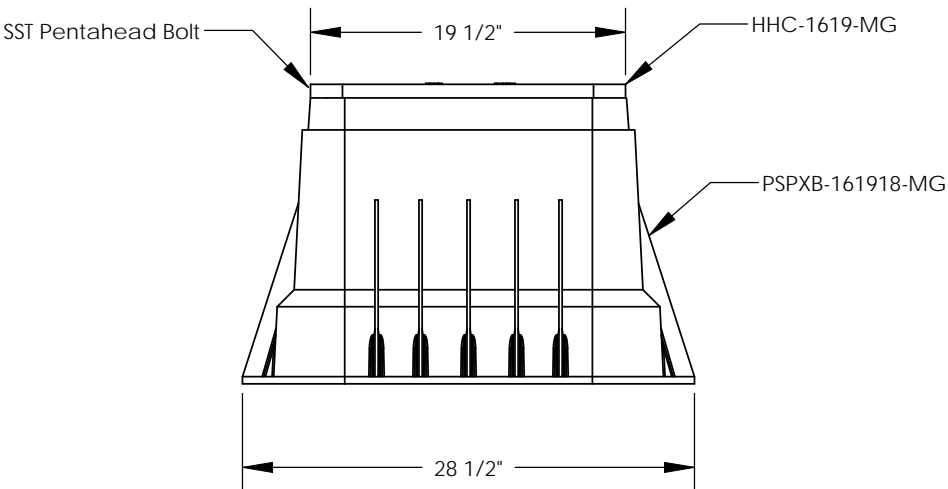
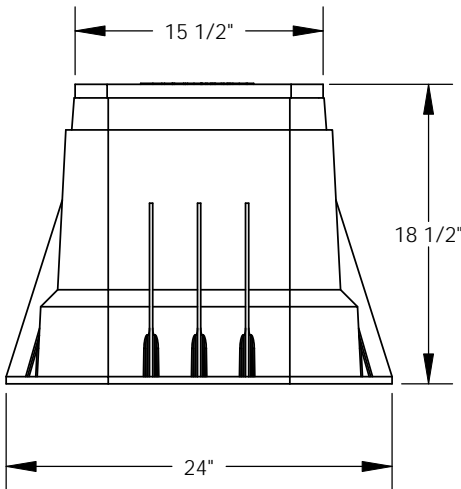
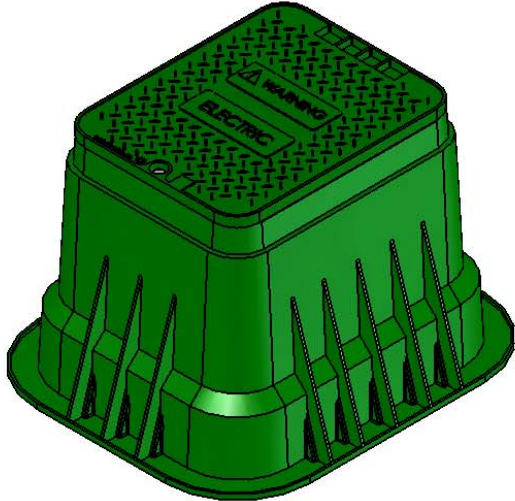
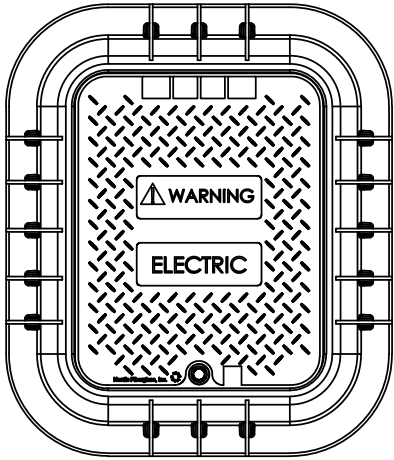

**PROPRIETARY AND CONFIDENTIAL**  
 THE INFORMATION CONTAINED IN THIS DRAWING IS THE SOLE PROPERTY OF NORDIC FIBERGLASS, INC. ANY REPRODUCTION IN PART OR AS A WHOLE WITHOUT THE WRITTEN PERMISSION OF NORDIC FIBERGLASS, INC. IS PROHIBITED.

Customer Name: N/A		
DIMENSIONS ARE IN INCHES TOLERANCES: ANGLES $\pm 1^\circ$ FRACTIONAL $\pm 1/2$ ONE PLACE DECIMAL $\pm .060$ TWO PLACE DECIMAL $\pm .030$ THREE PLACE DECIMAL $\pm .015$		
MATERIAL		
DRAWN	NAME	DATE
P.J.W.		03/01/06
CHECKED		--/--/--

<b>Nordic Fiberglass, Inc.</b>		
21415 US Hwy 75 NW, Warren, MN 56762 www.nordicfiberglass.com 218-745-5095 ph. --- 218-745-4990 fax		
PHH-161918-MG		
SIZE	ITEM ID:	REV.
<b>A</b>	03509.00	<b>REL-02</b>
SCALE:1:12	SHEET 1 OF 1	