

REVISIONS			
REV.	DESCRIPTION	DATE	APPROVED
REL-01		7/8/2008	
REL-02	Added 12 ABS-616 Rivets to Kit	3/18/2009	R.L.J.

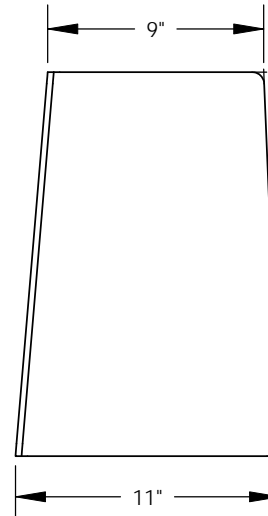
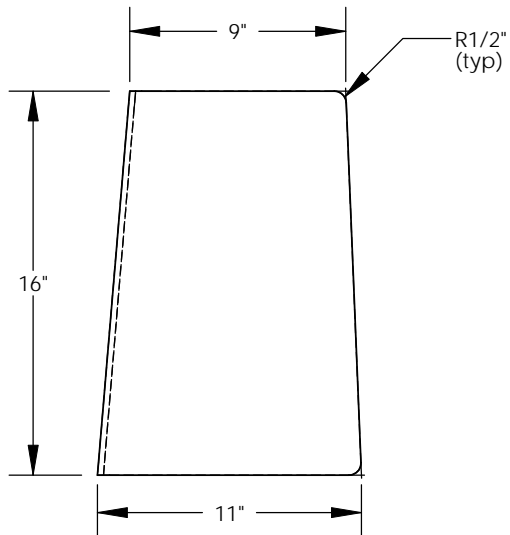
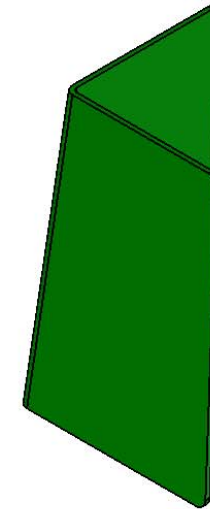
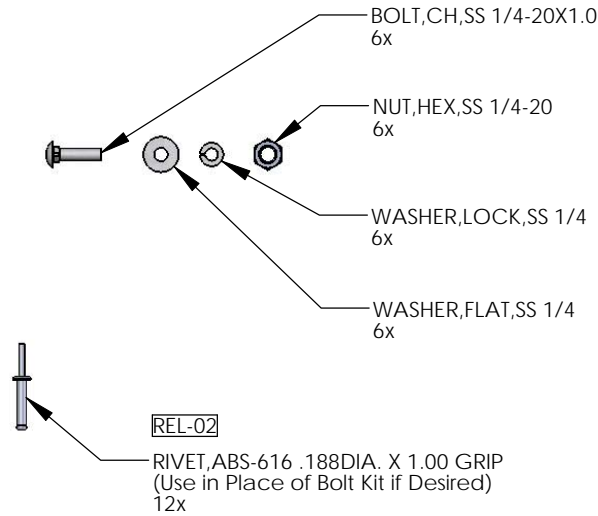
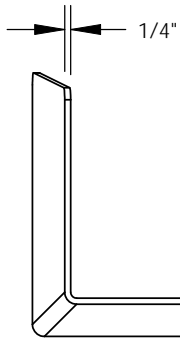

Notes:  
 Bolt/Rivet pattern to be determined and Drilled by Installer  
 Silicone Caulking used upon Installation  
 Rivet Gun Supplied by Installer for Rivet Installation

### Nordic Fiberglass, Inc.

21415 US Hwy 75 NW, Warren, MN 56762  
 www.nordicfiberglass.com  
 218-745-5095 ph. --- 218-745-4990 fax

NRK-3-MG, CORNER REPAIR KIT

**PROPRIETARY AND CONFIDENTIAL**  
 THE INFORMATION CONTAINED IN THIS DRAWING IS THE SOLE PROPERTY OF NORDIC FIBERGLASS, INC. ANY REPRODUCTION IN PART OR AS A WHOLE WITHOUT THE WRITTEN PERMISSION OF NORDIC FIBERGLASS, INC. IS PROHIBITED.

Customer Name: N/A		
DIMENSIONS ARE IN INCHES TOLERANCES: ANGLES ± 1° FRACTIONAL ± 1/2 ONE PLACE DECIMAL ± .060 TWO PLACE DECIMAL ± .030 THREE PLACE DECIMAL ± .015		
MATERIAL		
	NAME	DATE
DRAWN	M.F.K.	07/08/08
CHECKED	---	--/--/--

SIZE	ITEM ID:	REV.
<b>A</b>	03125.01	<b>REL-02</b>
SCALE:1:8		SHEET 1 OF 1