

REVISIONS			
REV.	DESCRIPTION	DATE	APPROVED
REL-01		2/26/2007	

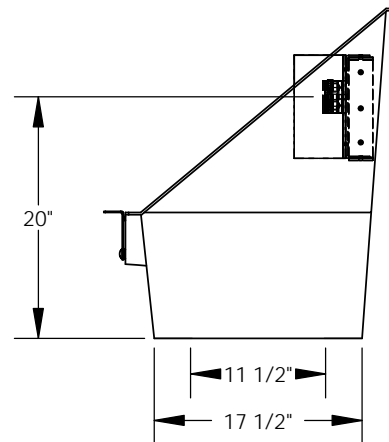
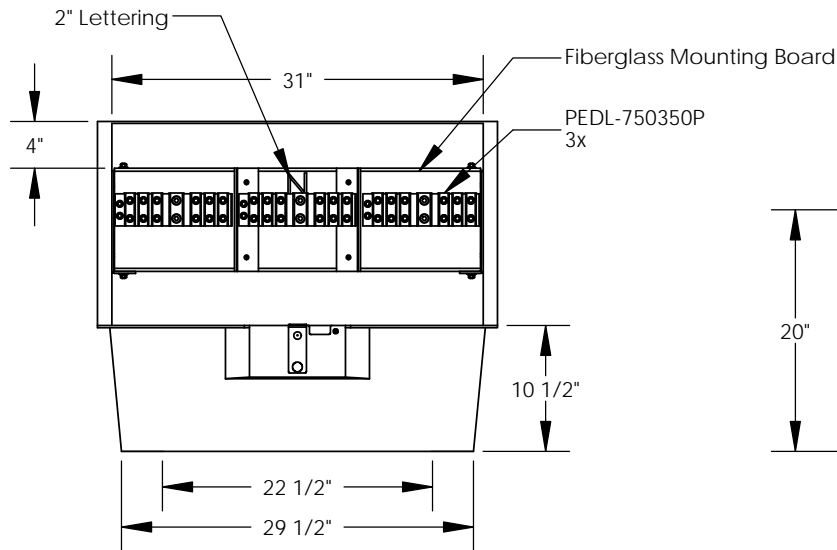
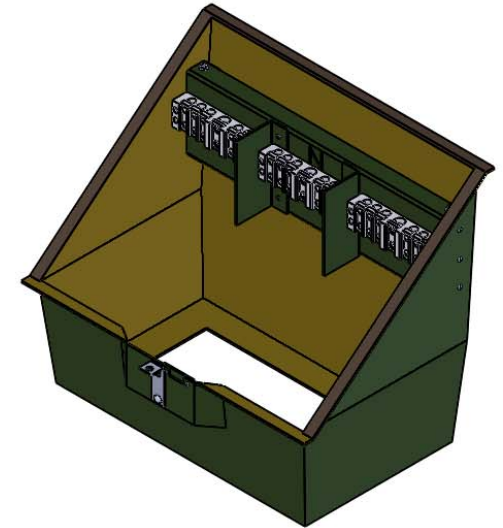
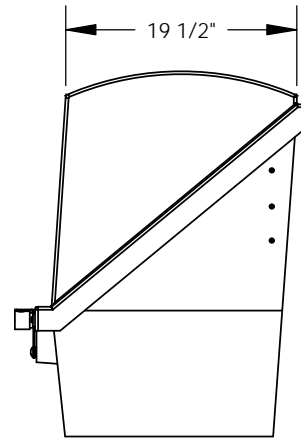
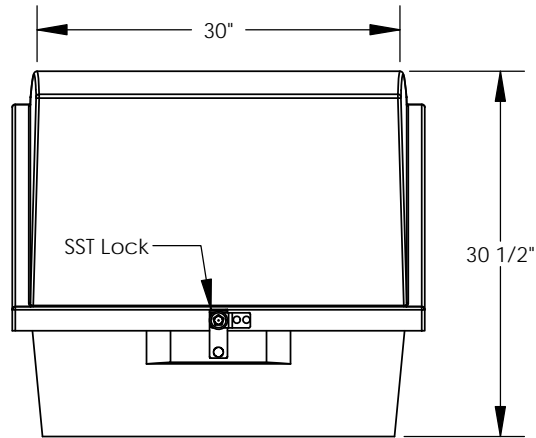

PROPRIETARY AND CONFIDENTIAL
 THE INFORMATION CONTAINED IN THIS DRAWING IS THE SOLE PROPERTY OF NORDIC FIBERGLASS, INC. ANY REPRODUCTION IN PART OR AS A WHOLE WITHOUT THE WRITTEN PERMISSION OF NORDIC FIBERGLASS, INC. IS PROHIBITED.

Customer Name: N/A		
DIMENSIONS ARE IN INCHES		
TOLERANCES: ANGLES ± 1°		
FRACTIONAL ± 1/2		
ONE PLACE DECIMAL ±.060		
TWO PLACE DECIMAL ±.030		
THREE PLACE DECIMAL ±.015		
MATERIAL		
DRAWN	P.J.W.	02/26/07
CHECKED	---	--/--/--

Nordic Fiberglass, Inc.		
21415 US Hwy 75 NW, Warren, MN 56762		
www.nordicfiberglass.com		
218-745-5095 ph. --- 218-745-4990 fax		
ND-301830-MG-X-L750350P-X		
SIZE	ITEM ID:	REV.
A	02750.09	REL-01
SCALE:1:16	SHEET 1 OF 1	