

REVISIONS			
REV.	DESCRIPTION	DATE	APPROVED

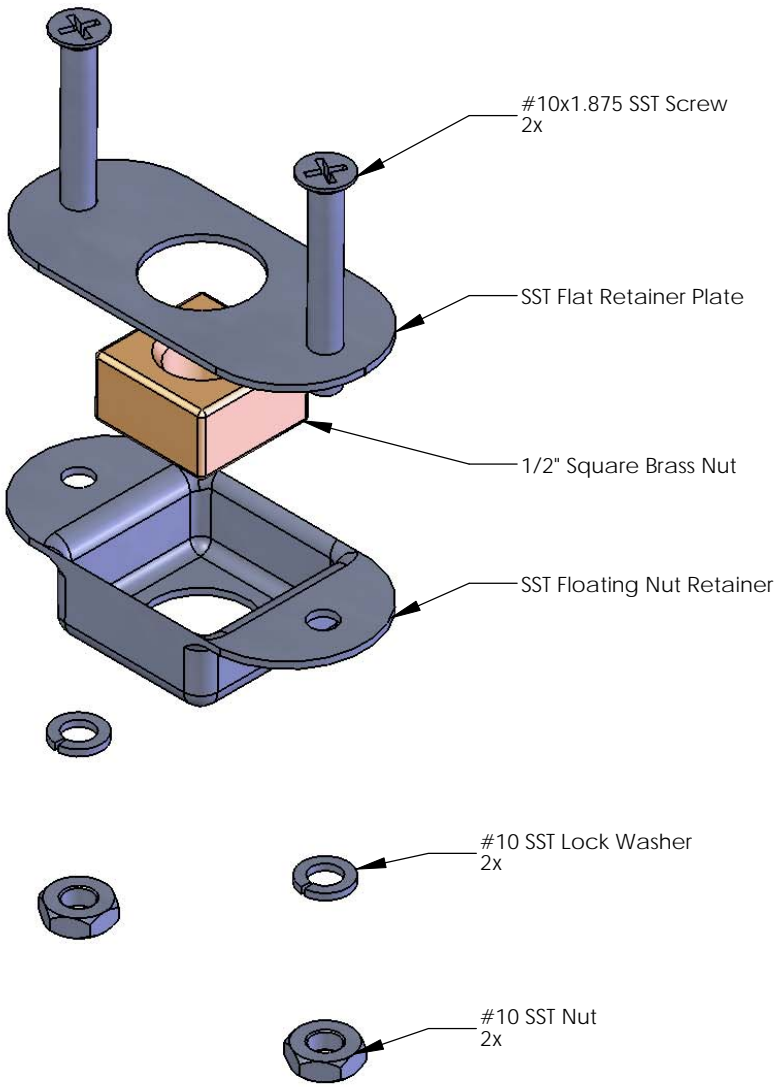

**Nordic Fiberglass, Inc.**

21415 US Hwy 75 NW, Warren, MN 56762  
 www.nordicfiberglass.com  
 218-745-5095 ph. --- 218-745-4990 fax

FN-12

**PROPRIETARY AND CONFIDENTIAL**  
 THE INFORMATION CONTAINED IN THIS DRAWING IS THE SOLE PROPERTY OF  
 NORDIC FIBERGLASS, INC. ANY REPRODUCTION IN PART OR AS A WHOLE  
 WITHOUT THE WRITTEN PERMISSION OF NORDIC FIBERGLASS, INC. IS PROHIBITED.

Customer Name: N/A		
DIMENSIONS ARE IN INCHES		
TOLERANCES: ANGLES $\pm 1^\circ$		
FRACTIONAL $\pm 1/2$		
ONE PLACE DECIMAL $\pm .060$		
TWO PLACE DECIMAL $\pm .030$		
THREE PLACE DECIMAL $\pm .015$		
MATERIAL	NAME	DATE
DRAWN	P.J.W.	05/10/07
CHECKED	---	--/--/--

SIZE	ITEM ID:	REV.
<b>A</b>	00259.10	<b>REL-01</b>
SCALE:1:1	SHEET 1 OF 1	